

MAXIN

The image shows the word "MAXIN" in a bold, grey, sans-serif font. A bright yellow, curved swoosh underline starts under the 'M', loops under the 'A' and 'X', and ends under the 'N'. The swoosh has a slight curve and a thin tail at the end.



New Science at BioMAX and MicroMAX

Thomas Ursby
MAX IV Laboratory

MAX IV Laboratory

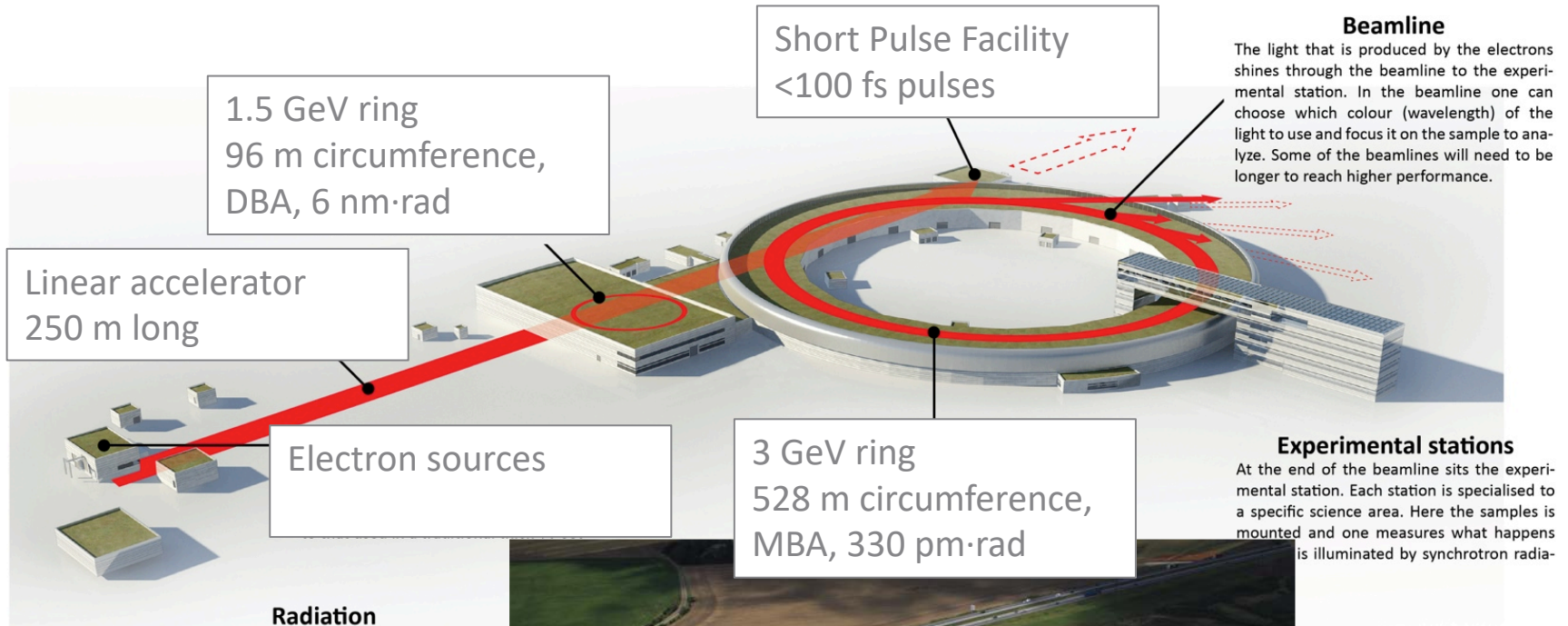

Radiation

The electrons in the accelerator create a small amount of background radiation when the machine is operated. When the machine is switched off the remaining radiation as no radioactive material is produced. The accelerator is built into concrete and thus one can work freely in all other areas of the laboratory. If someone would enter the accelerator area the machine would automatically shut down.



BioMAX – Macromolecular crystallography

BioMAX

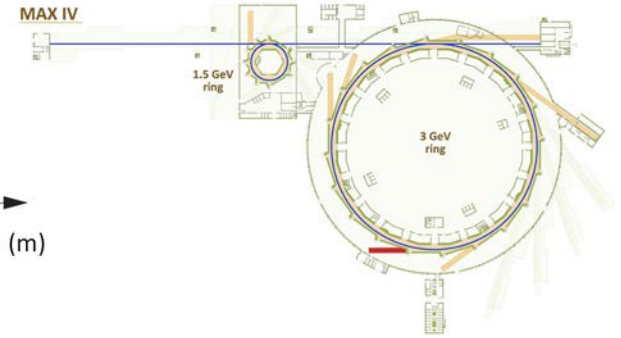
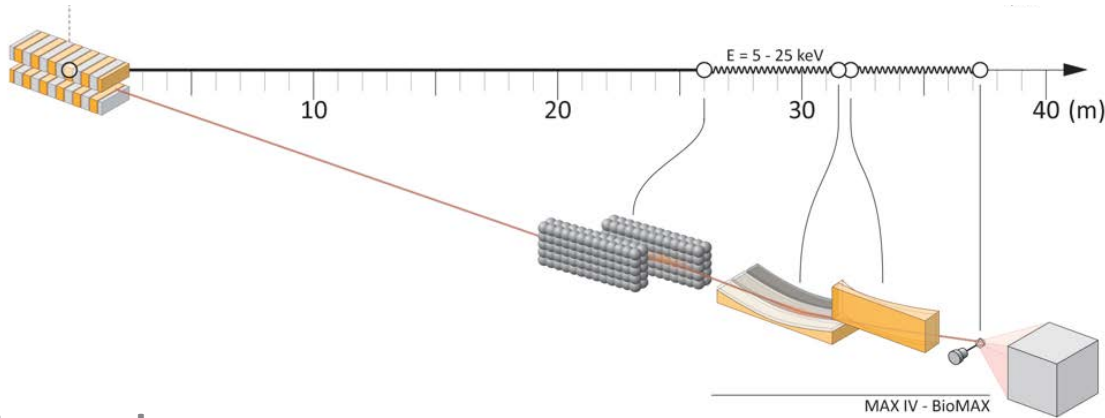

Beamline goals:

- *Support all relevant techniques for MX*
- Beam characteristics:
 - Small focus ($20 \times 5 \mu\text{m}^2$ h_{xv} FWHM)
 - Low divergence ($0.1 \times 0.1 \text{ mrad}^2$)
 - High flux (2×10^{13} phot/s \times 0.1% bw)
- Ultra stable beam
- Large energy range (5-25 keV)
- Short data collection times / high throughput
- High degree of automation

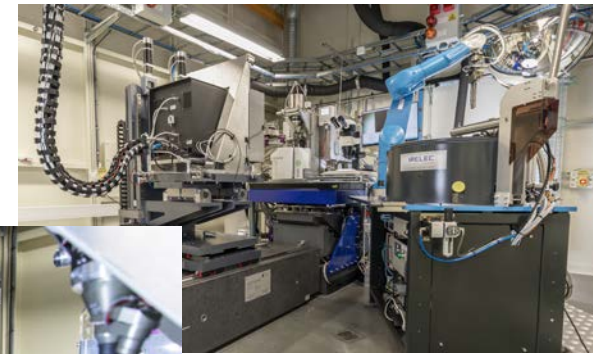

In regular user operation since 2017

BioMAX user operation



1st HVE-injector experiment with PI Heidelberg



DRAW GOOD CUP OF COFFEE DRAW GOOD BEV...



Fiat MaxIV-trip for the Krzyzaj group (Uls)!



Great day @ BioMAX DEB-Lab, Aarhus Uni, DK



Structural biology at 297-18 BMG, LV. Thanks a lot!!

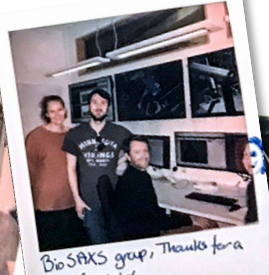

BioSAXS group, Thanks for a great night wcp



Thanks Uwe & Ana for all help at this lovely Beamline @ Jerry/SLU-Uppsala 2018



Thank you! It was a great experience and time here! Ana and Topi

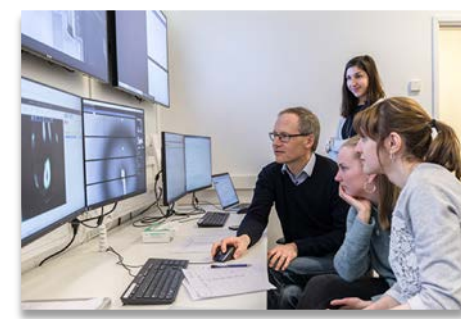
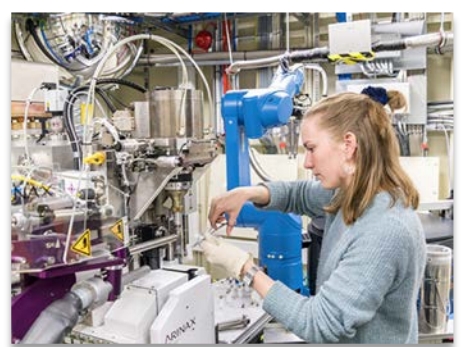

Thanks, Tjallingii!! So many nice talks!!! @ Niels. -Eliav Julian



Thanks for the great course and day our first crystals! Stegmann Andrea L. Lucamad 18/01/2018



Happy users from the Stenroq group - Stockholm university 01/03/2018



Thanks for helping us with our new crystals! Ulfhies, Anja, Johannes



...



Novo Nordisk users February 2018



Happy users from the CBB Beamline



Serial Crystallography at BioMAX

Serial crystallography at synchrotron sources

Cryogenic loop rotation

Gati et al. 2014

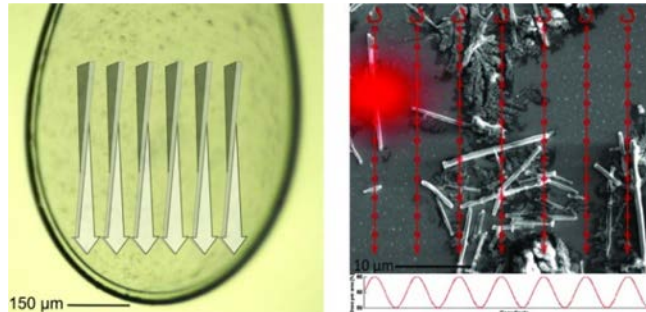

Glass capillary

Stellato et al., 2014

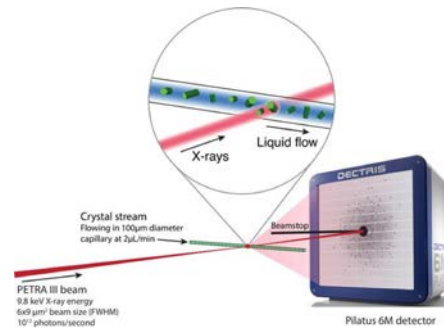

First injector-based experiments

Nogly et al., 2014
Botha et al, 2015

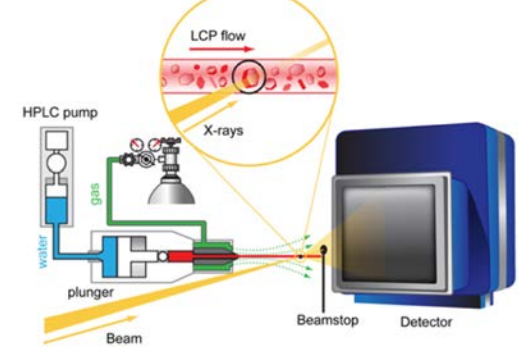

Fixed target systems

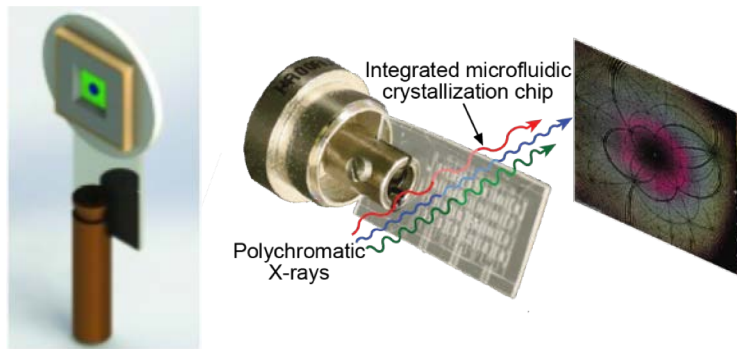

Silicon nitride membranes

Coquelle et al. 2015

Microfluidics chips

Sui et al., 2016

Ultrasonic acoustic levitation

S.Tsujino, T. Tomizaki, 2016

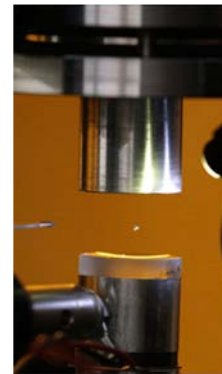

Moving tape

Beyerlein K. et al., 2017

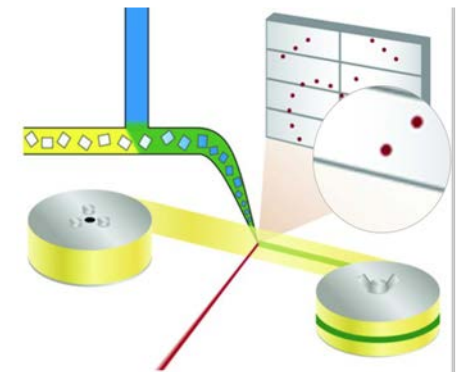

Serial Crystallography Sample Delivery

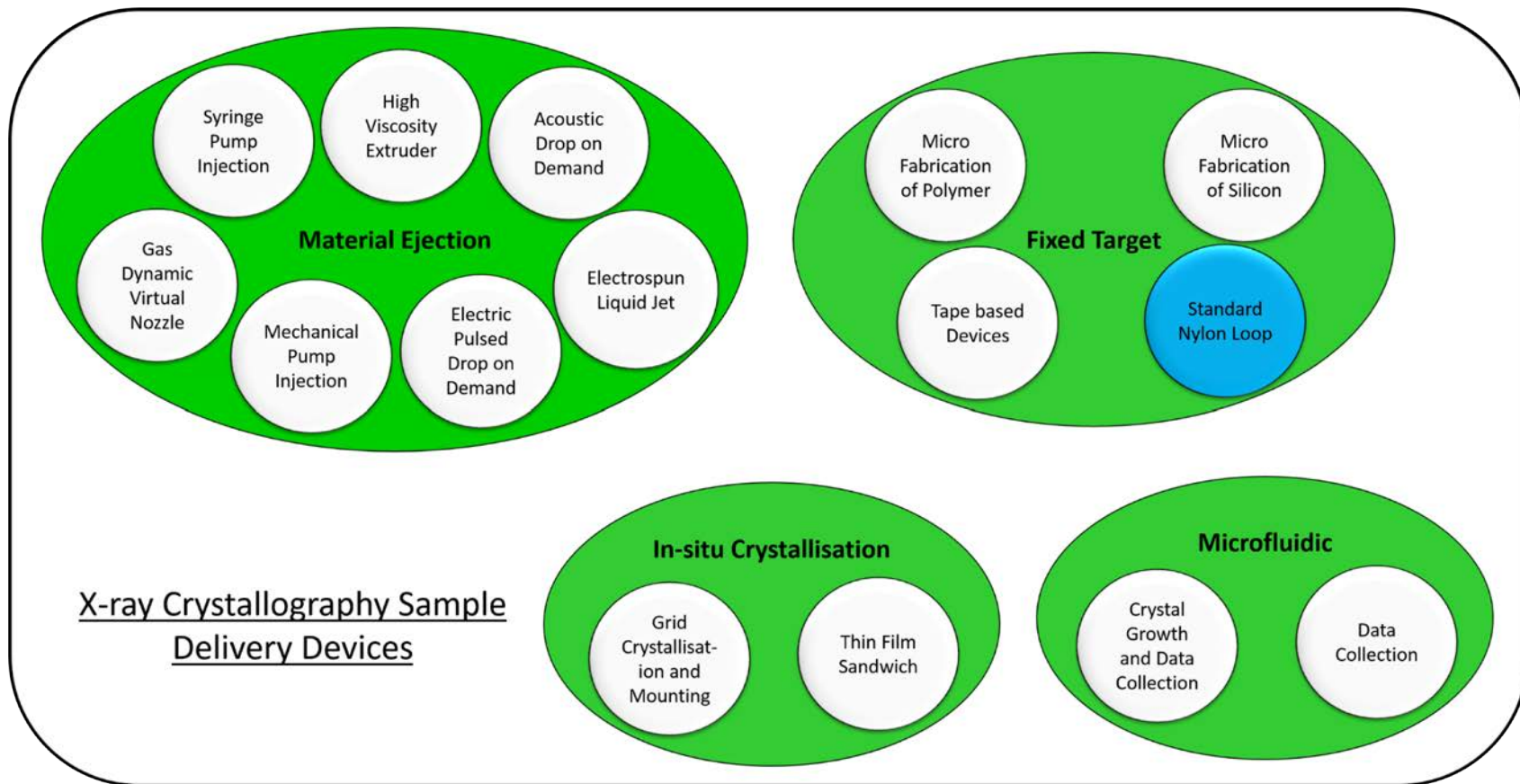
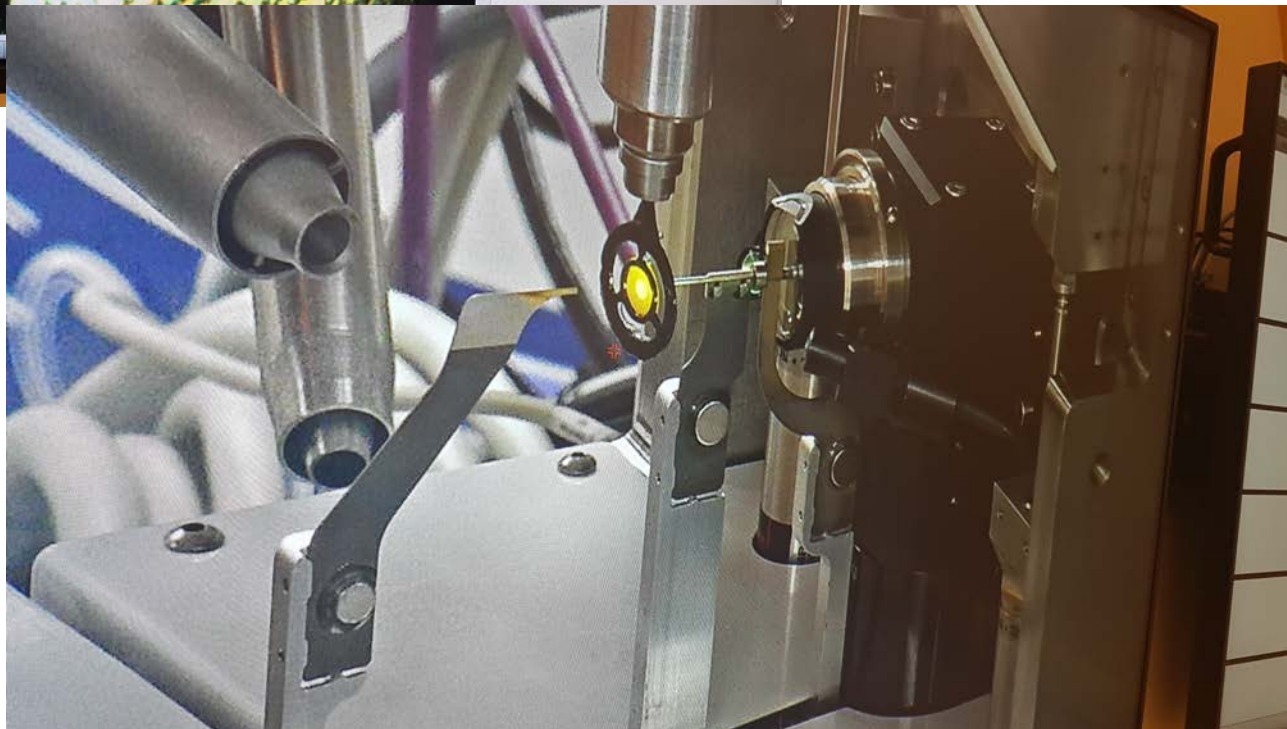
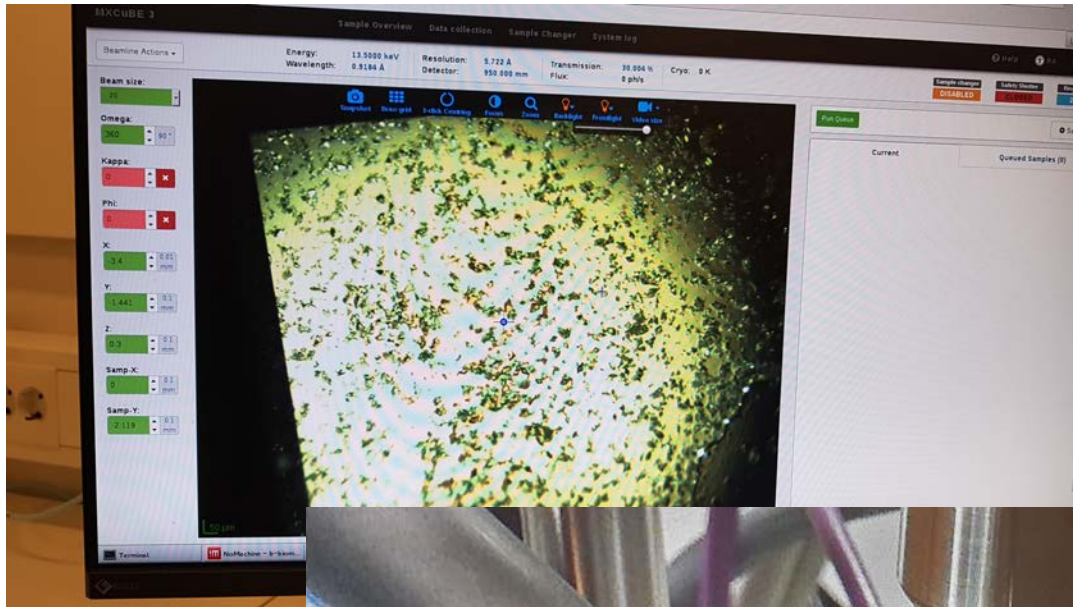

Figure Ross Friel

Overview X-ray Serial Crystallography Sample Deliver Devices

Fixed target using the MD3



Fixed Target – Roadrunner

Alke Meents *et al.*, CFEL/DESY

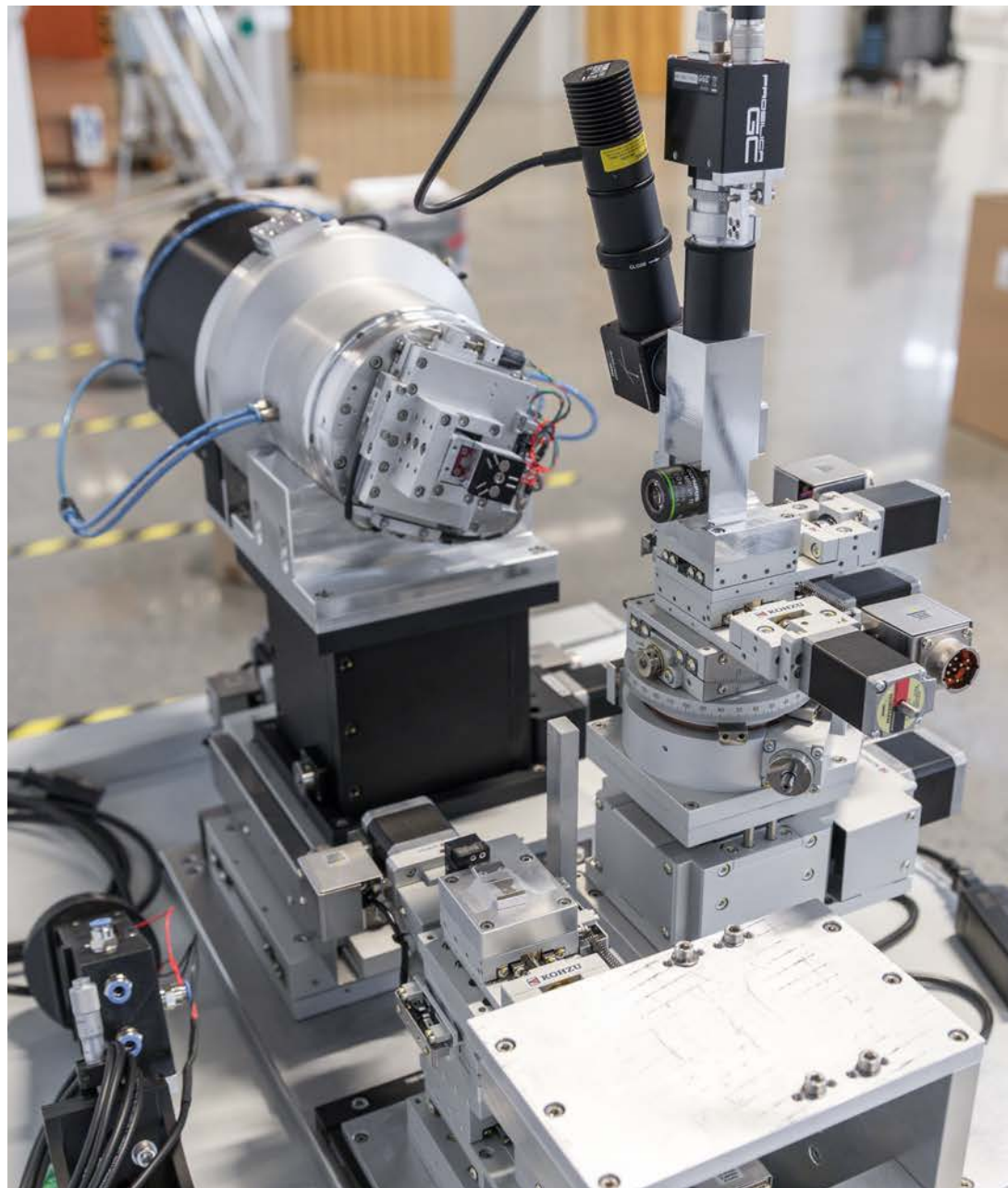
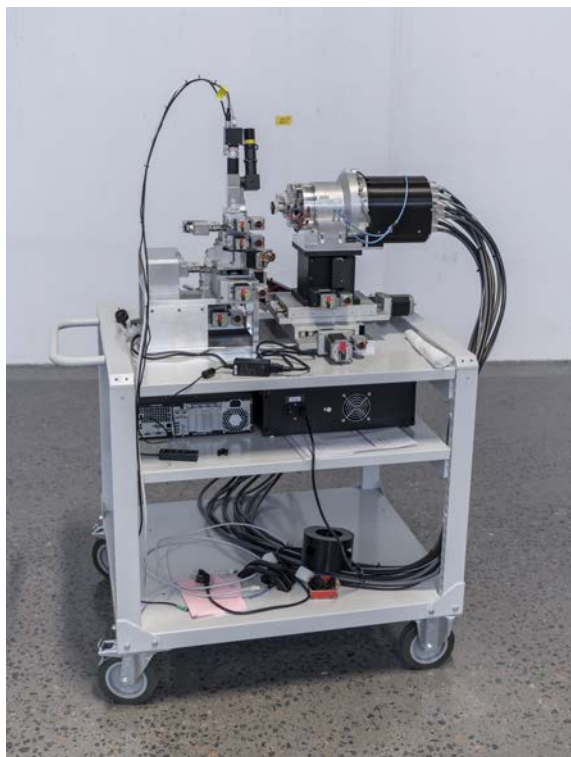

Fixed-target using Roadrunner

Roadrunner 3 at BioMAX, CAD view
In collaboration with Alke Meents CFEL/DESY

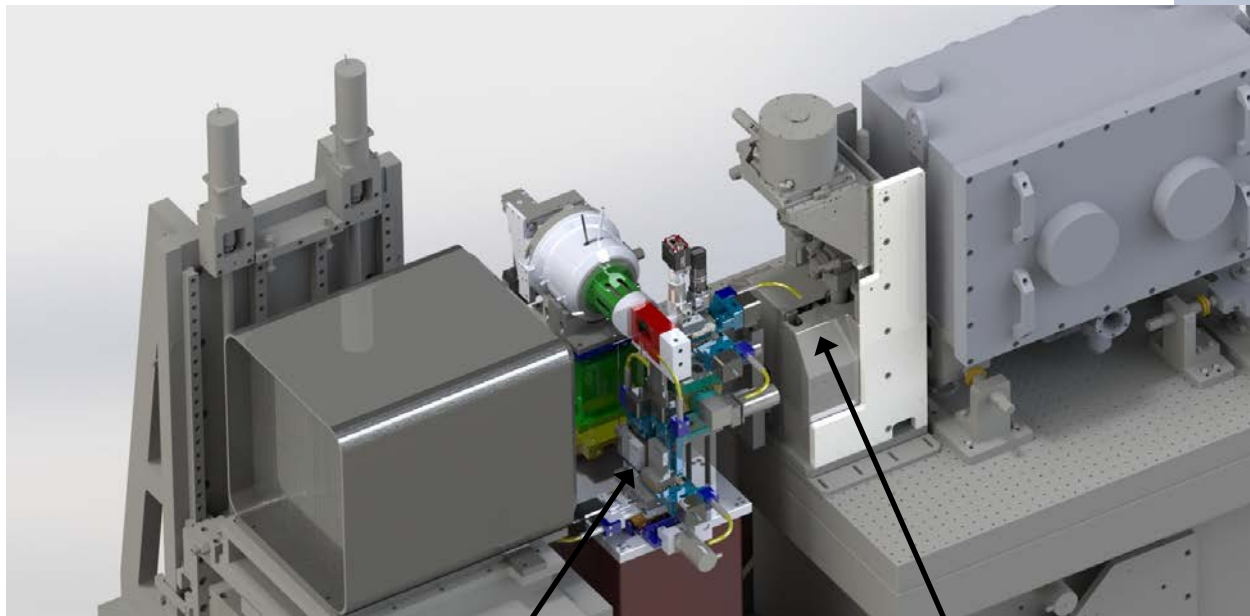
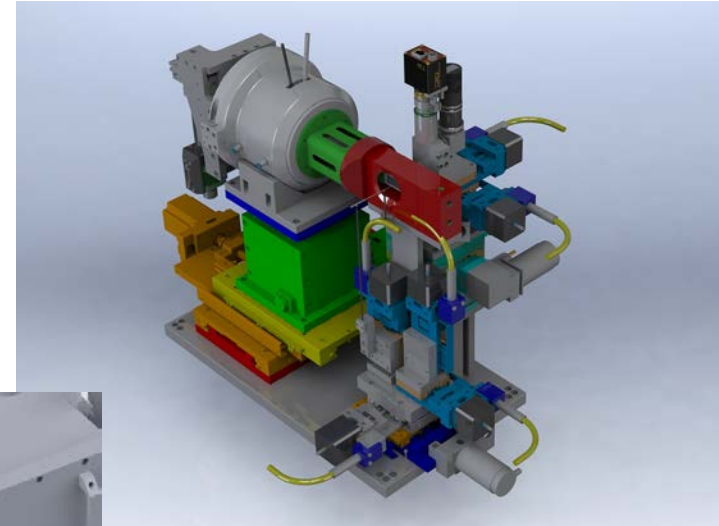

Roadrunner
scanning setup

MD3 diffractometer

High viscosity extrusion injector at BioMAX

Volume of the injector 130 μL

Pressurized via HPLC pump

Flow rate 1 μL per minute

Exposure per crystal 2.8 ms

Frame rate 133 Hz

Low sample consumption

*Different matrixes can be used
(grease, LCP, etc.)*

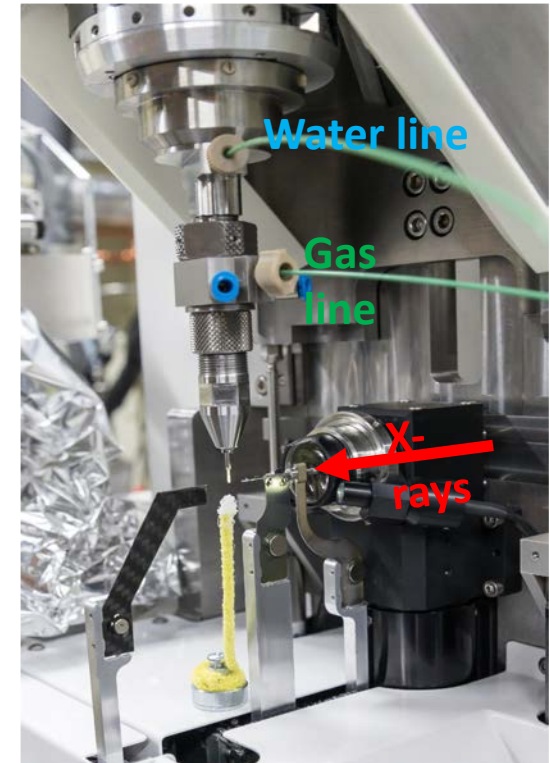
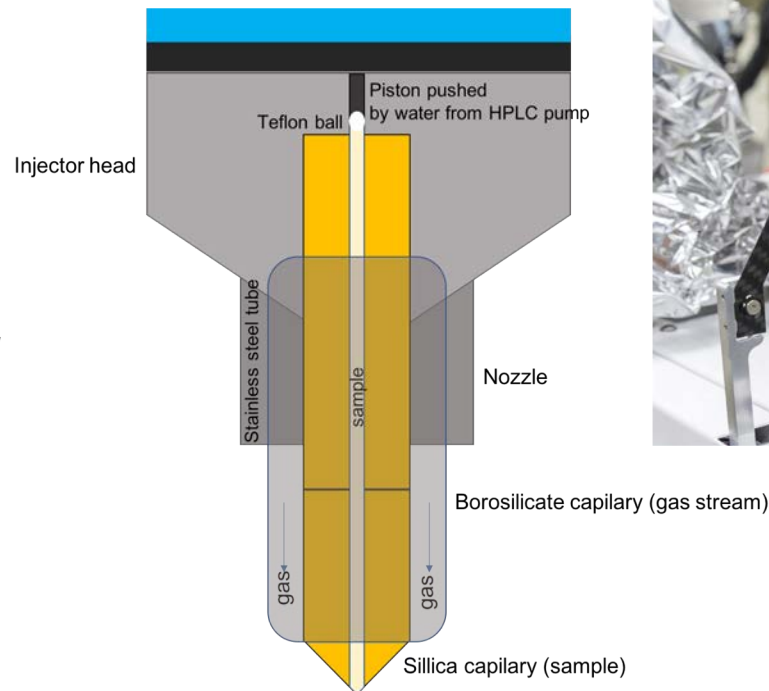

***HVE injector developed at MPI Heidelberg
by Bruce Doak / Ilme Schlichting groups***

First HVE-injector experiment at BioMAX

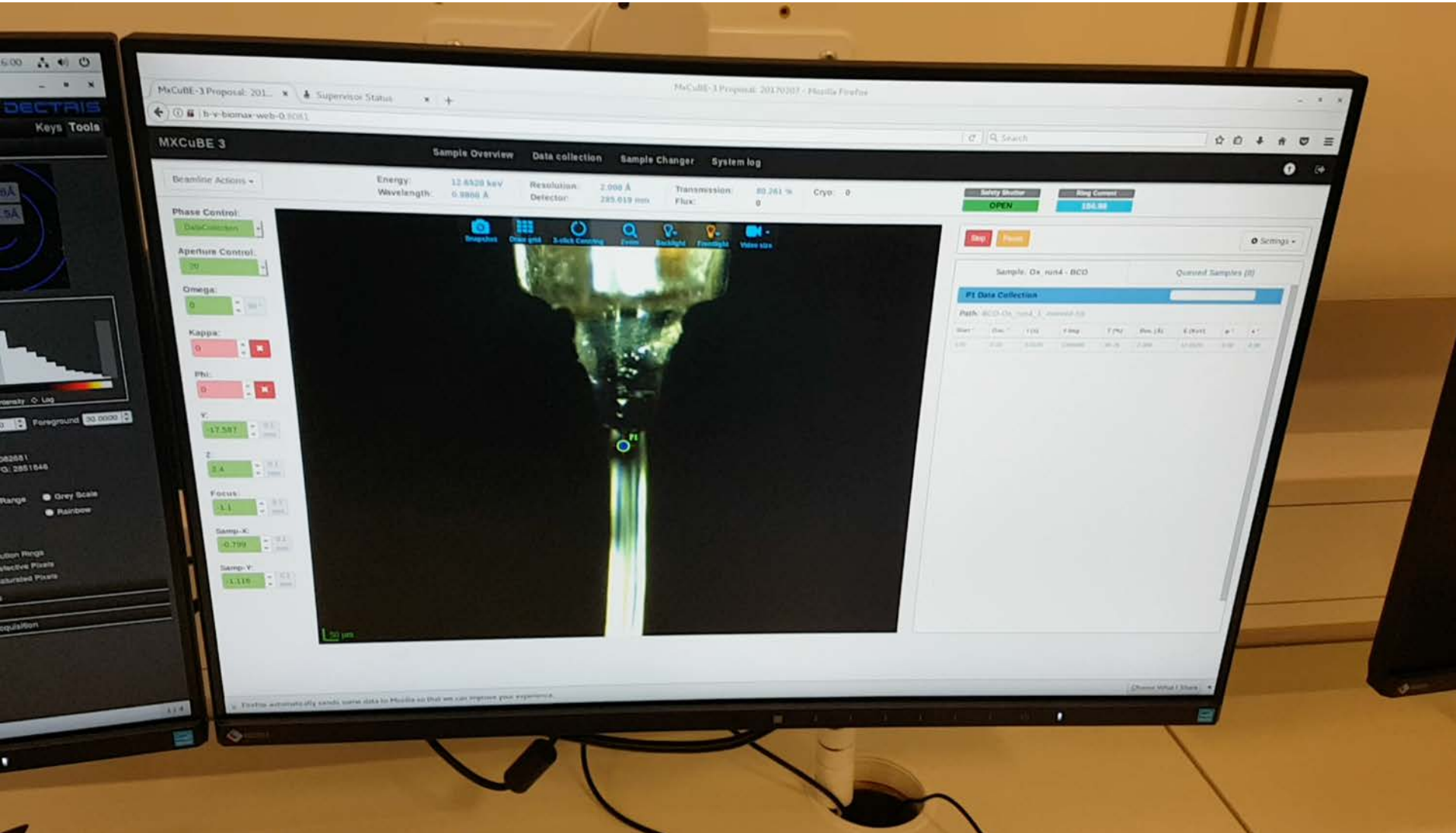

First HVE-injector experiment at BioMAX

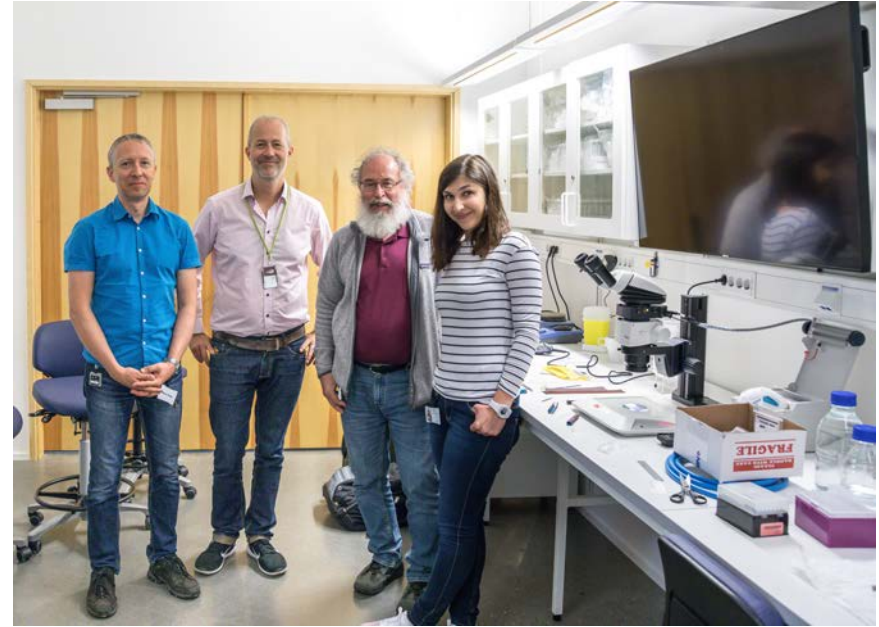

Robert Shoeman & Marco Kloos, MPI Heidelberg
Anastasya Shilova & Uwe Mueller, MAX IV

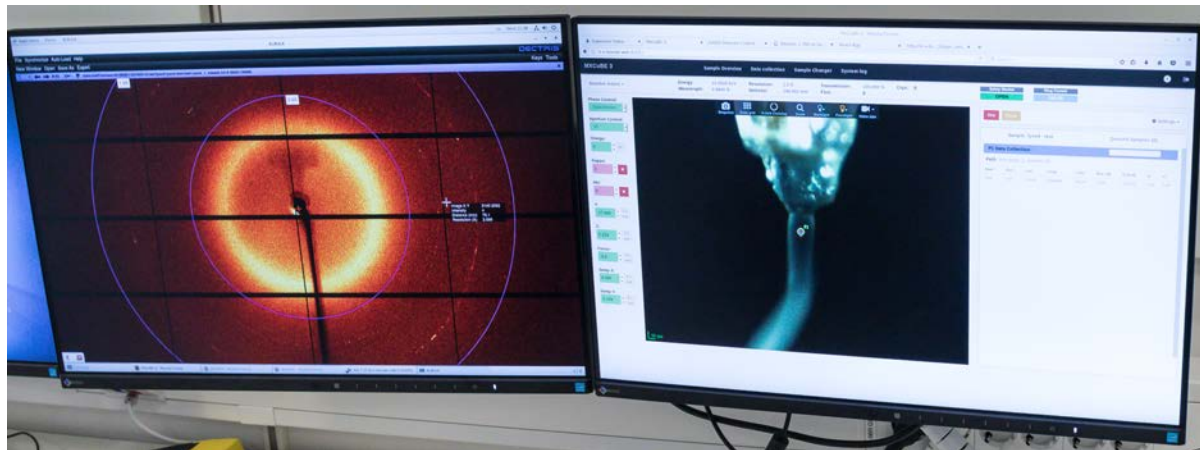

Data and extrusion viewer during experiment

First HVE-injector experiment at BioMAX

Average crystal size=10 μm

122,000 collected images

19,511 indexed images

Overall SNR = 4.8

Completeness = 100%

Overall $R_{\text{split}} = 14\%$

Resolution = 1.9 \AA

$R_{\text{work}} = 0.18$

$R_{\text{free}} = 0.20$

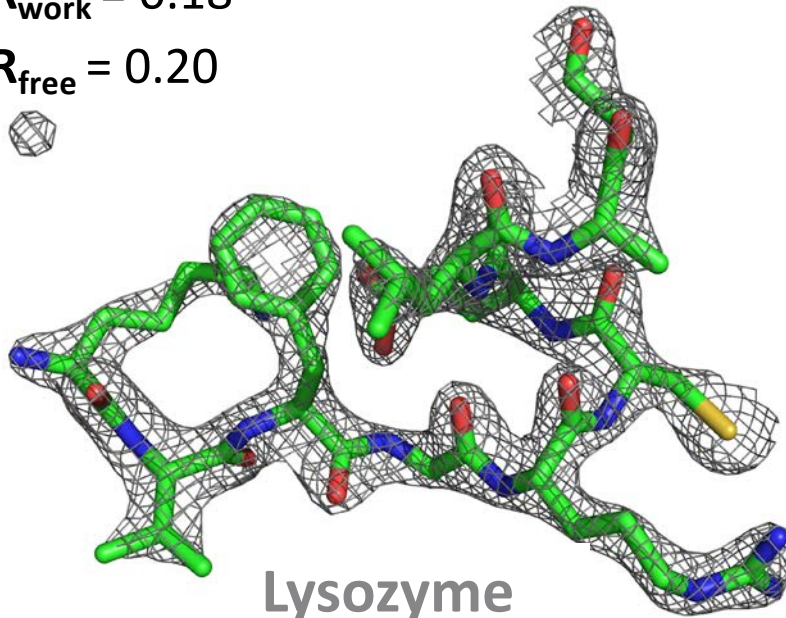

Sorting of data (NanoPeakCell)

Merging and indexing of data
(CrystFEL)

Phasing and refinement of data
(Phenix, Coot)

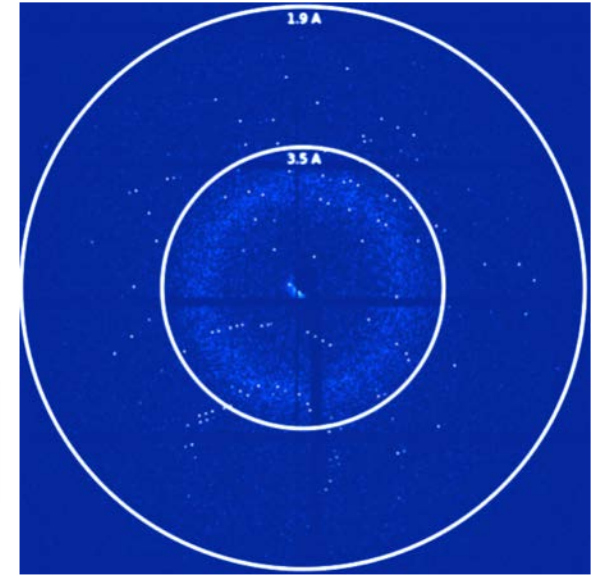

2nd HVE exp. – Neutze / Brändén groups

4 - 7 June 2018

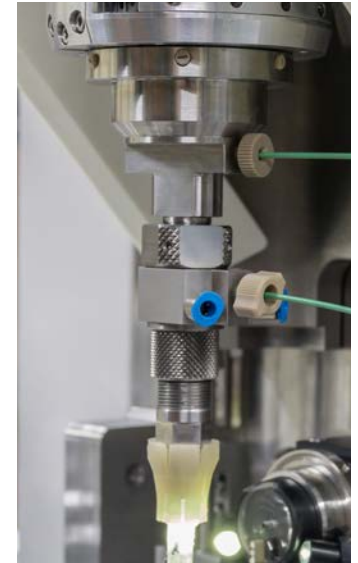

MPI HVE injector

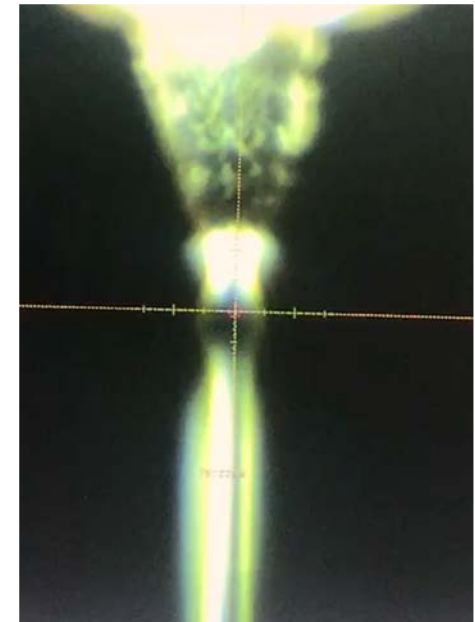

- 3 projects injected
- 10 TB+ of data

First user HVE experiment at BioMAX

Average crystal size = 15 μm
253,766 collected images
6,513 indexed images

Overall SNR = 2.7

Completeness = 100%

Overall R_{split} = 34 %

Resolution = 3.8 \AA

R_{work} = 0.32

R_{free} = 0.36



Cytochrome c oxidase enzyme

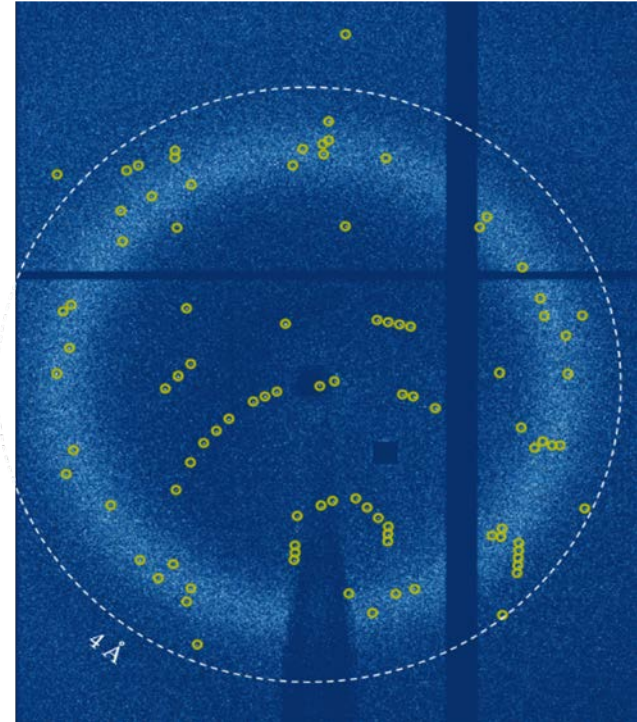

Experiment was performed with user groups from University of Gothenburg (groups of Richard Neutze and Gisela Brändén)

HVE injector experiments at BioMAX Neutze / Brändén groups



HVE injector experiments at BioMAX



MXCuBE

Separate branch (internal triggering of detector, 2D-centring and few other modifications)

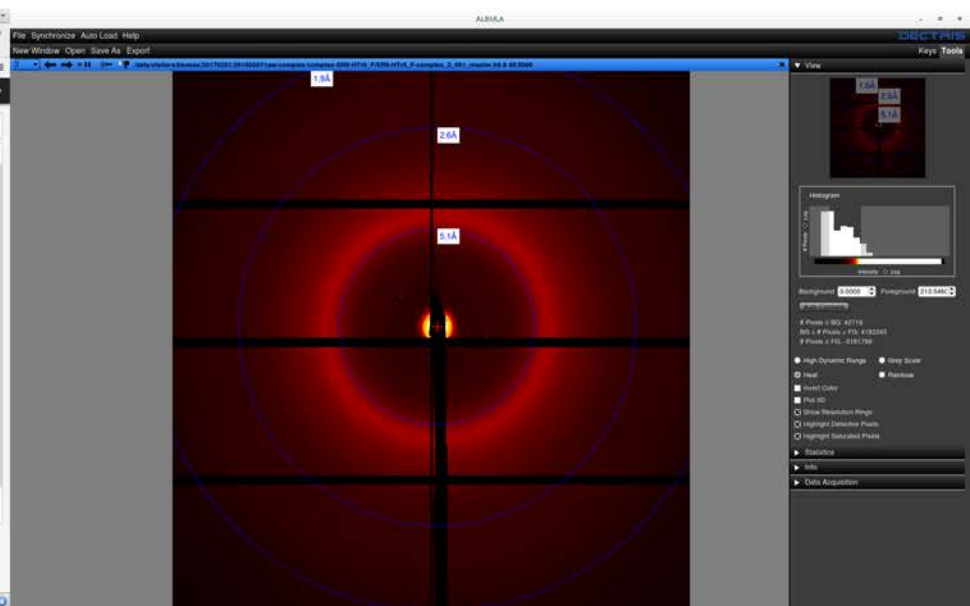
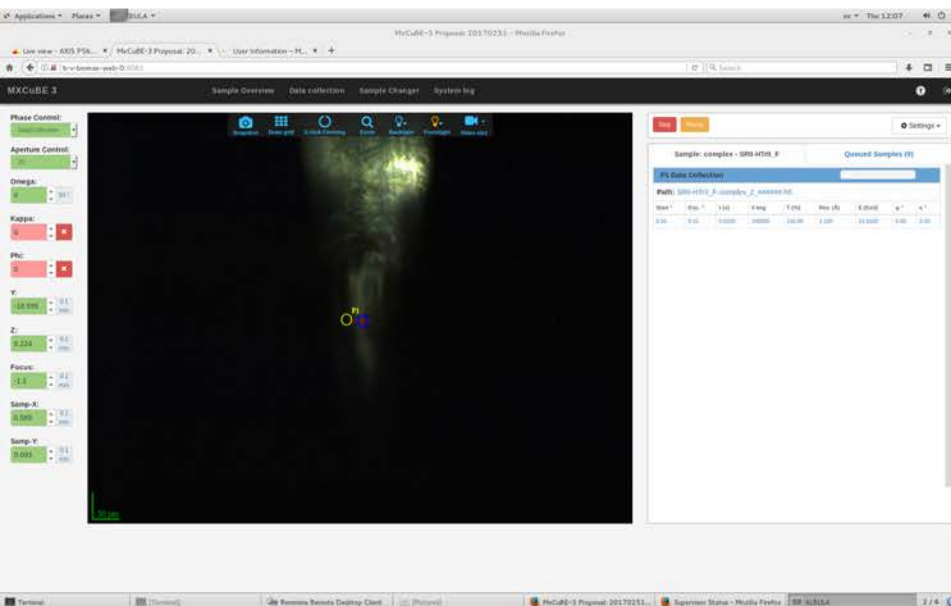
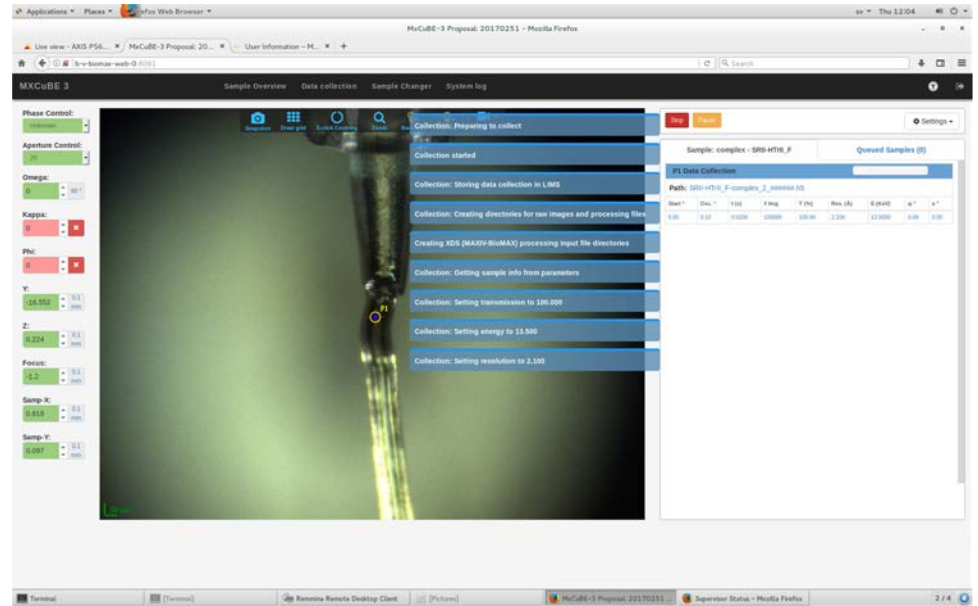

MXCuBE

Improvements:

Add feedback of hit rate and processing statistics

A lot of small improvements could make the switch between oscillation and SSX experiments easier

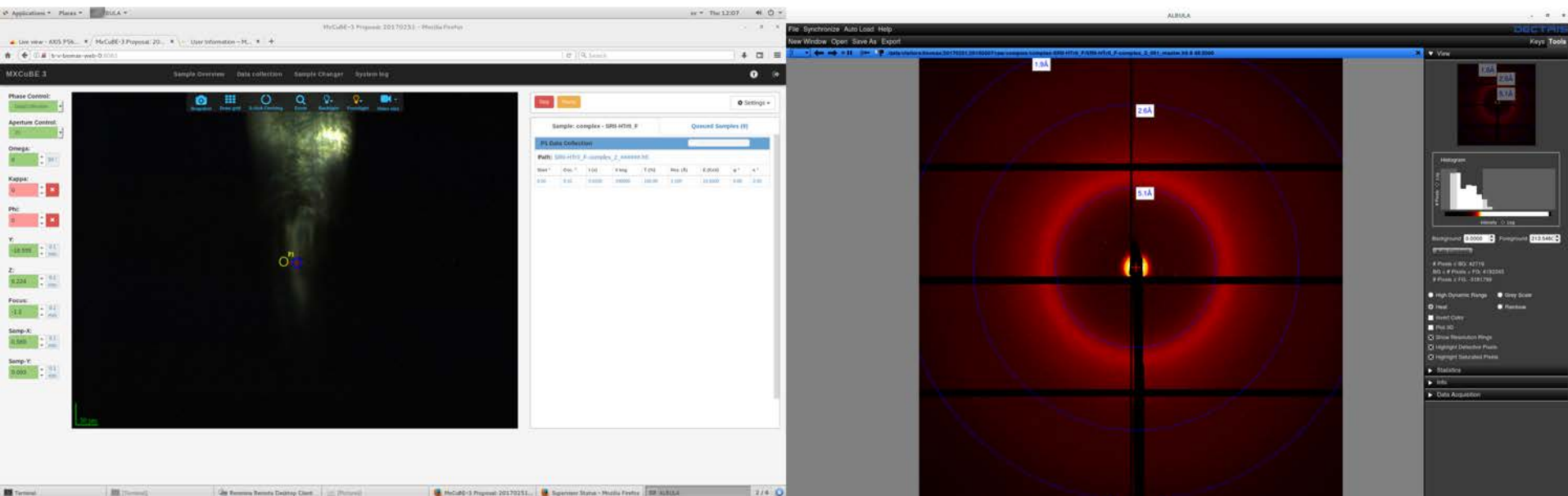
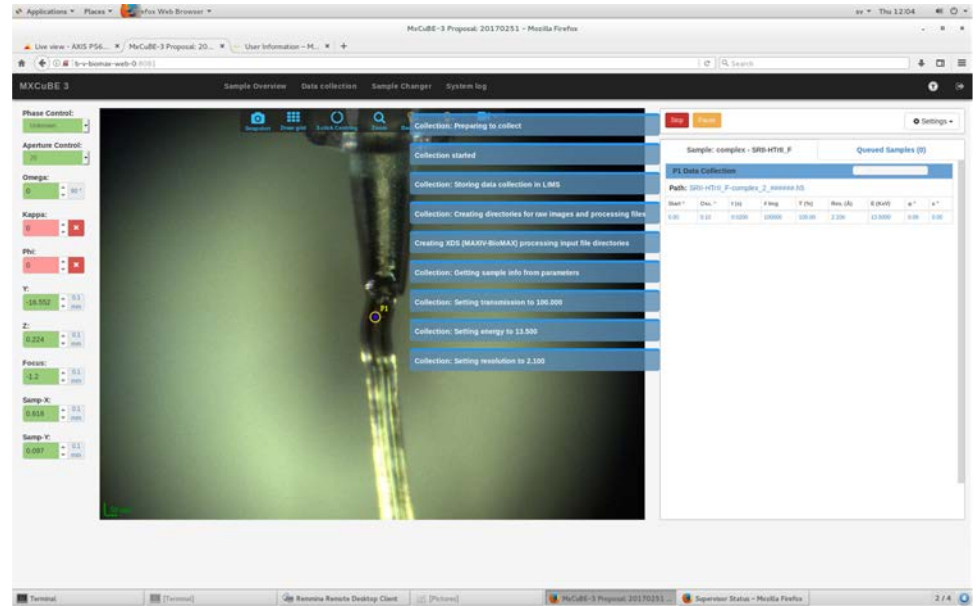

Serial Crystallography at BioMAX

Bruce Doak, Ilme Schlichting *et al.*

Max Planck Institute for Medical Research, Heidelberg

Richard Neutze, Gisela Brändén *et al.*

University of Gothenburg

Alke Meents *et al.*, CFEL/DESY

Anastasya Shilova, Uwe Mueller, Jie Nan, Ross Friel,

Mirko Milas *et al.*

MAX IV MX Group

MicroMAX – Microfocus MX at MAX IV
MicroMAX – Serial Crystallography at MAX IV

MicroMAX Funding



The Novo Nordisk Foundation announced funding of MicroMAX on January 25th, 2018 (4 years of construction + 10 years of operation)

Beamlines

3.0 GeV Ring

NanoMAX

Nano-focus & coherence

DanMAX

Imaging & diffraction

Balder

EXAFS & RIXS

ForMAX

Wood based material

CoSAXS

SAXS & coherence

BioMAX

Protein structure

MicroMAX

Protein structure

Veritas

Excitations in solids & liquids

HIPPIE

Operando spectroscopy

SoftiMAX

X-ray microscopy & coherence

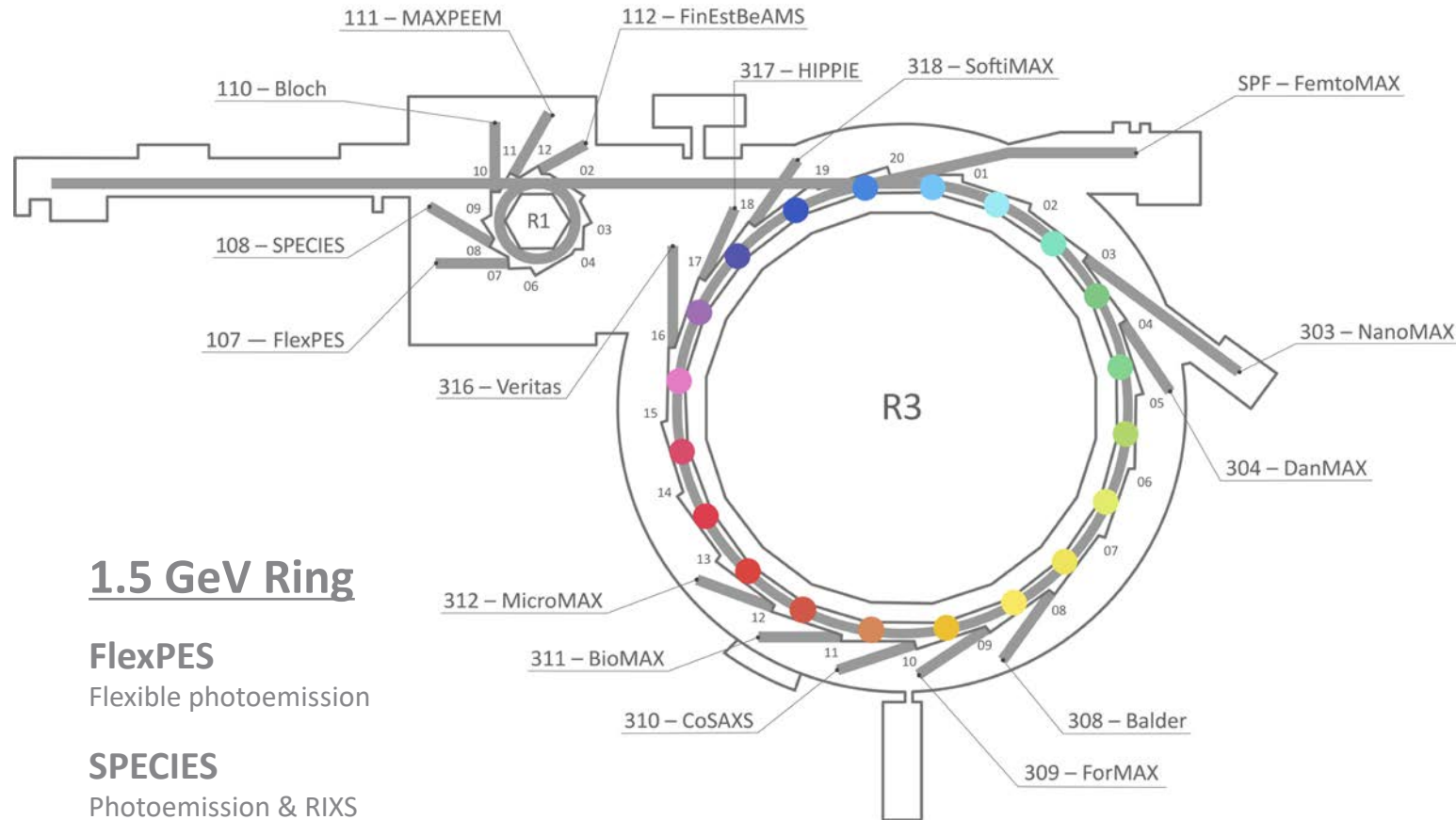

1.5 GeV Ring

FlexPES

Flexible photoemission

SPECIES

Photoemission & RIXS

Bloch

Electronic structure surfaces

MAXPEEM

Microscopy of surfaces

FinEstBeAMS

Gas phase & luminescence

3.0 GeV Linac

FemtoMAX

Ultra-fast diffraction & spectroscopy

Legend:

User operation

Commissioning

Construction

MicroMAX – Scope

Study structure and function of macromolecules with a high brilliance X-ray beam and new beam delivery methods that will allow us to study:

- structures from macromolecules that cannot be crystallized to sufficient size or quality for other beamlines,
- room temperature structures,
- time resolved structures down to the micro- and millisecond timescales

A rapidly evolving field triggered by the development at XFELs

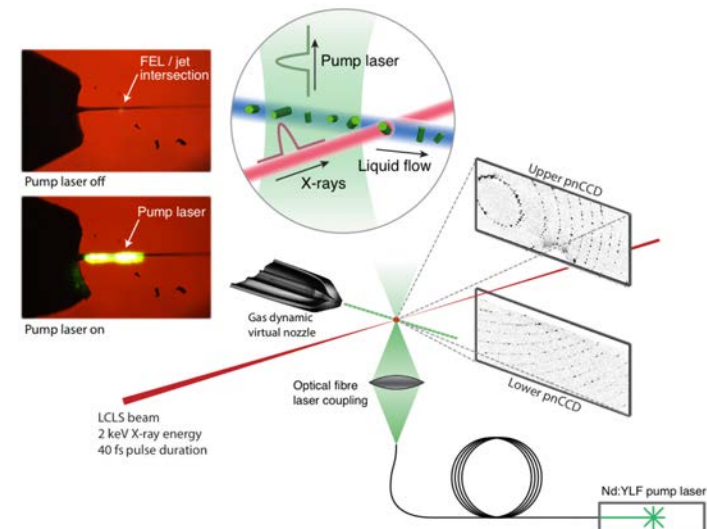
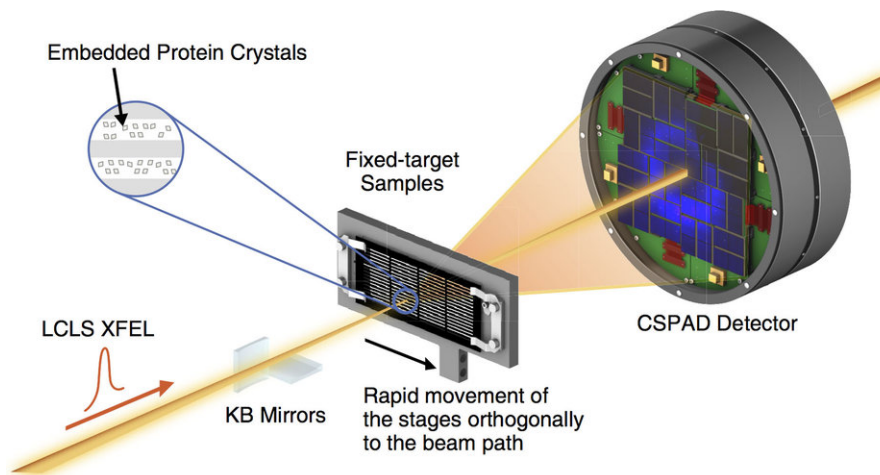

Hunter, M. S. et al. Fixed-target protein serial microcrystallography with an x-ray free electron laser. *Sci. Rep.* 4, (2014)

Aquila, A. et al. Time-resolved protein nanocrystallography using an X-ray free-electron laser. *Opt. Express* 20, 2706–2716 (2012)

MicroMAX – Specifications

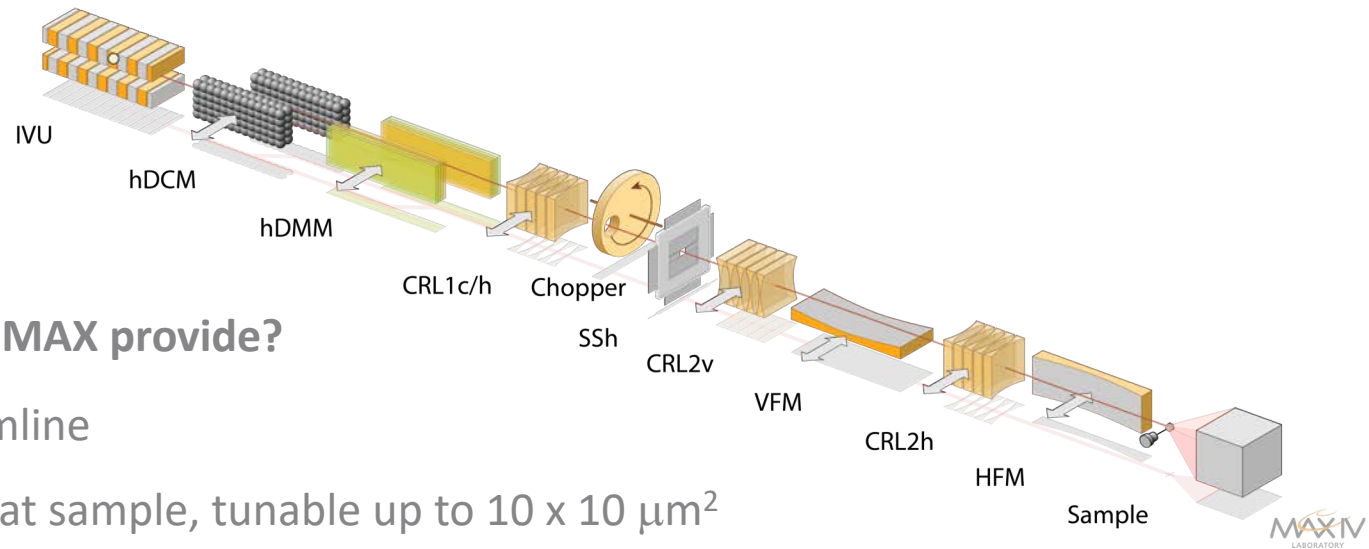

What should MicroMAX provide?

- Microfocus beamline
- $1 \times 1 \mu\text{m}^2$ beam at sample, tunable up to $10 \times 10 \mu\text{m}^2$
- Photon flux 10^{13} - 10^{15} photons/second (monochromatic / wider bandpass)
- Energy range 5 – 20 keV
- Exploratory setup (serial crystallography)
- Traditional setup (goniometry, sample environment)
- Optimal source for most demanding projects

MicroMAX Optics

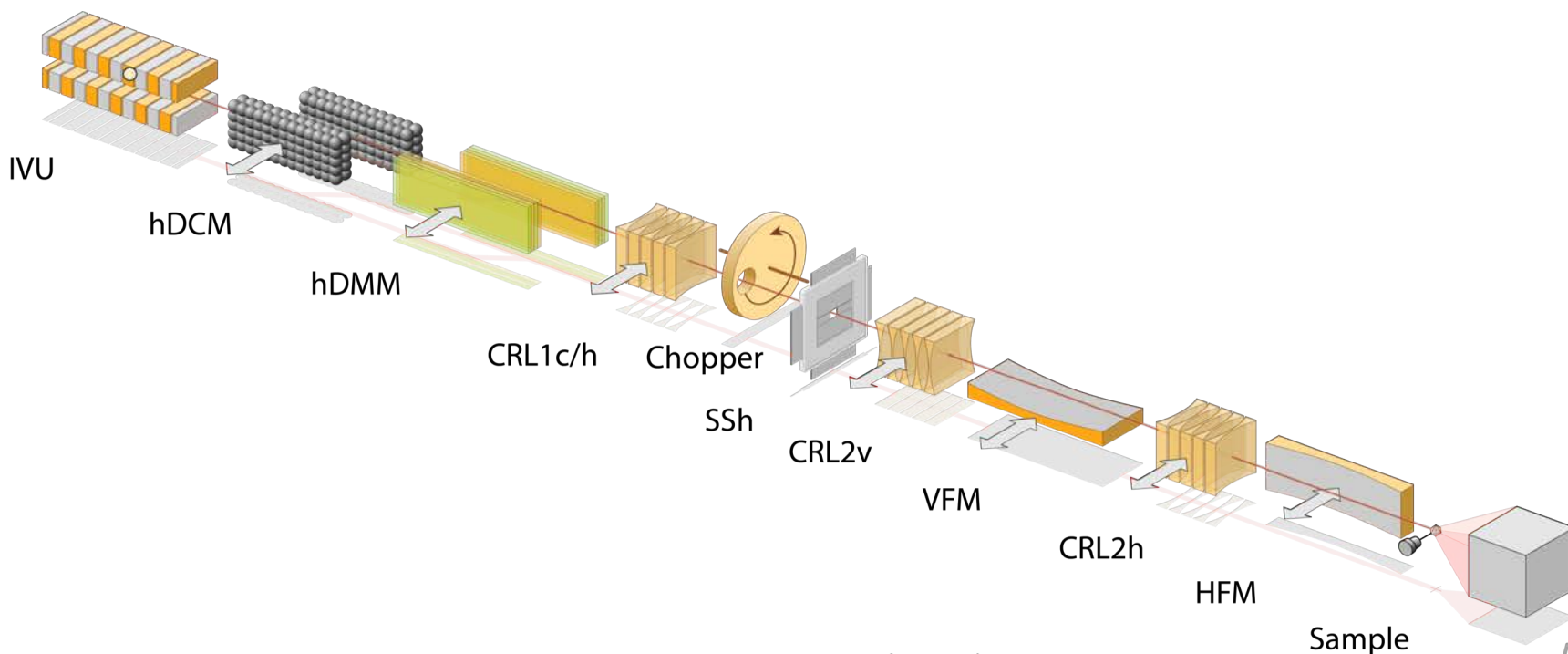

<i>Optics component</i>	<i>Position (centre) m</i>
<i>In-vacuum undulator (IVU)</i>	0
<i>Crystal monochromator (hDCM)</i>	24.7
<i>Multilayer monochromator (hDMM)</i>	25.5
<i>Collimating lenses (CRL1c)</i>	26.5
<i>Horizontally focusing lenses (CRL1h)</i>	26.9 ± 0.05
<i>Chopper</i>	32.0
<i>Horizontal secondary source (SSh)</i>	32.5
<i>Vertically focusing lenses (CRL2v)</i>	37.9 ± 0.1
<i>Vertically focusing mirror (VFM)</i>	38.4
<i>Horizontally focusing lenses (CRL2h)</i>	38.8 ± 0.03
<i>Horizontally focusing mirror (HFM)</i>	39.2
<i>Diffraction: Sample position EH1</i>	40.0

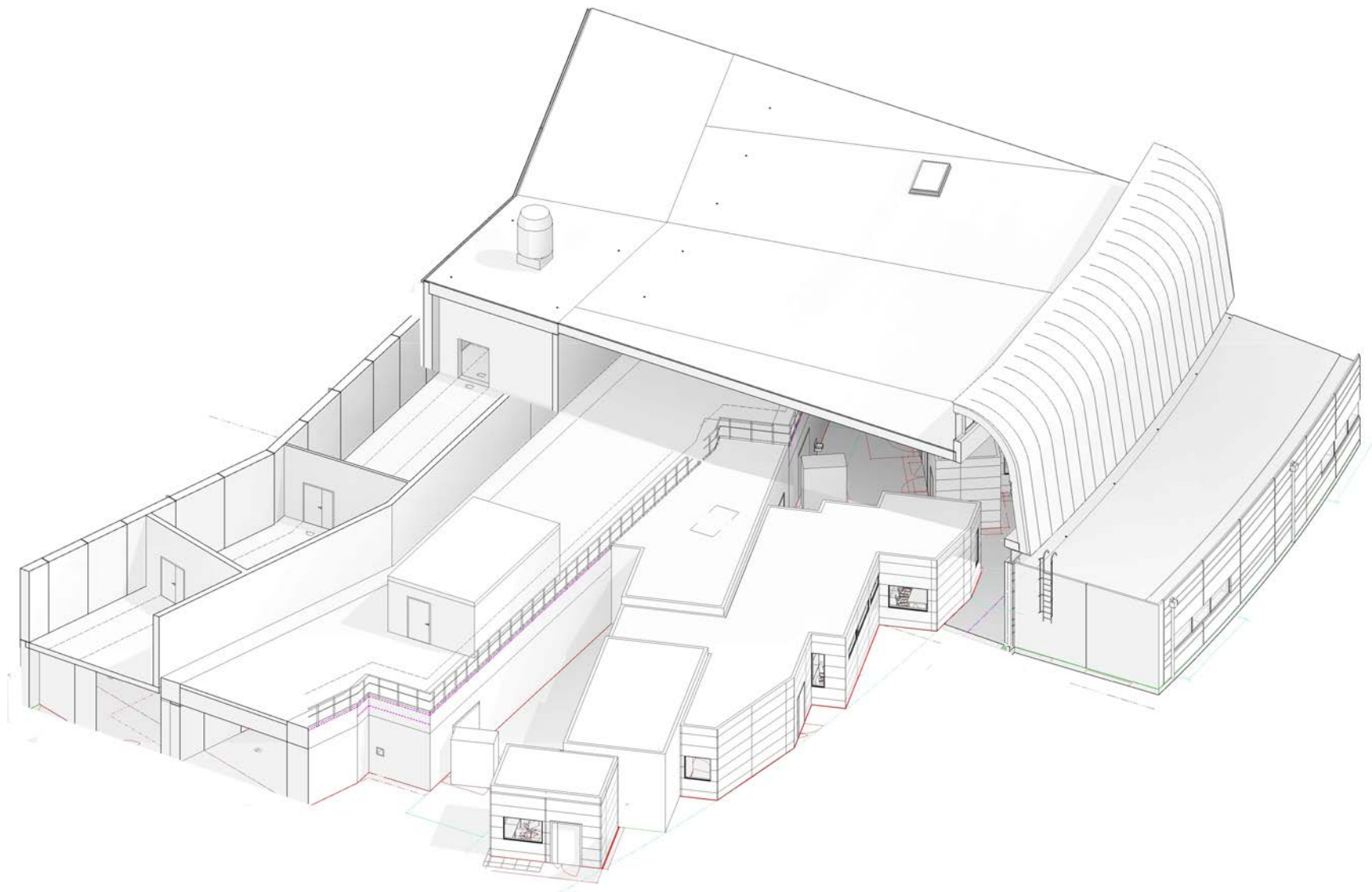

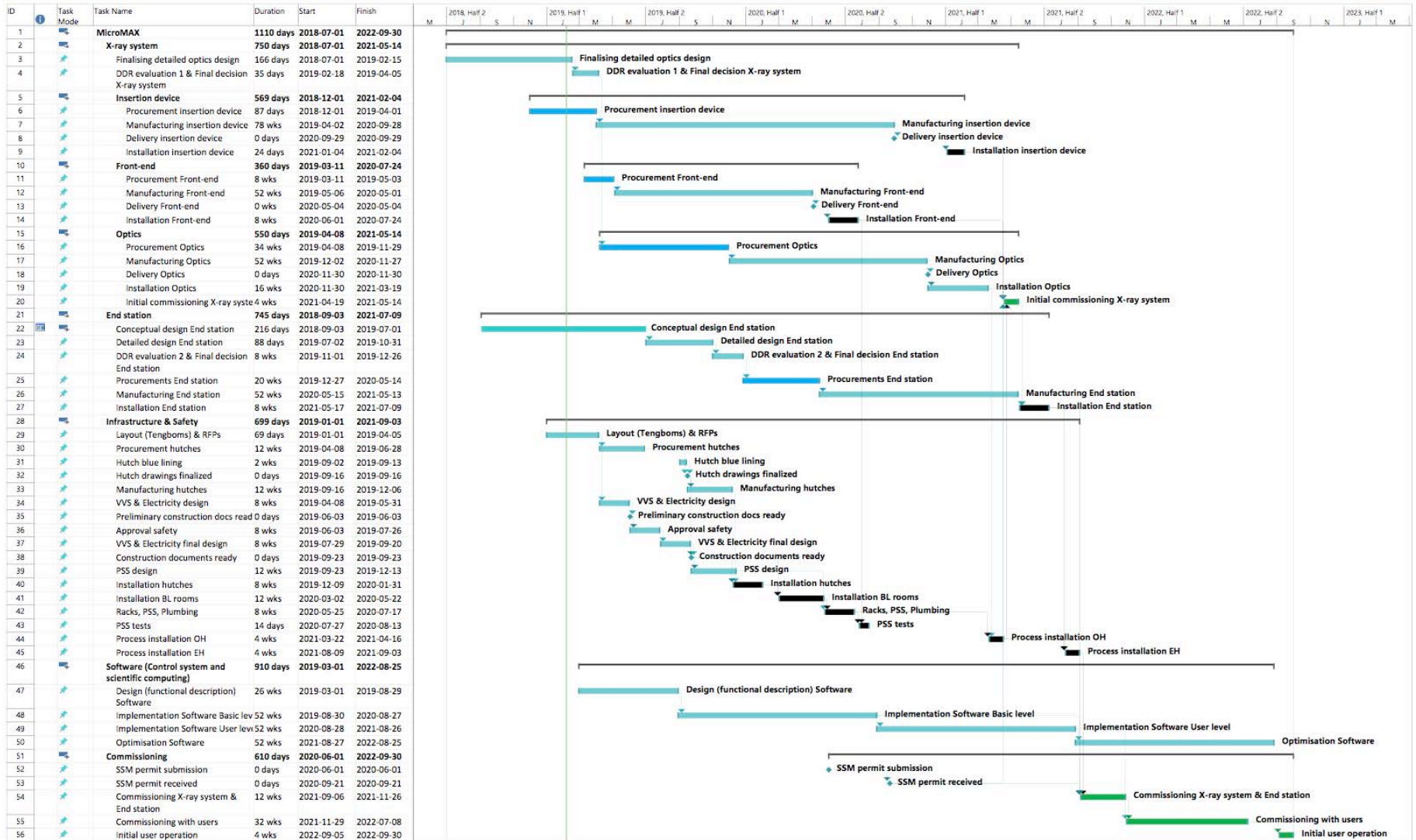

Project: MicroMAX v2
Date: 2019-02-06



MicroMAX

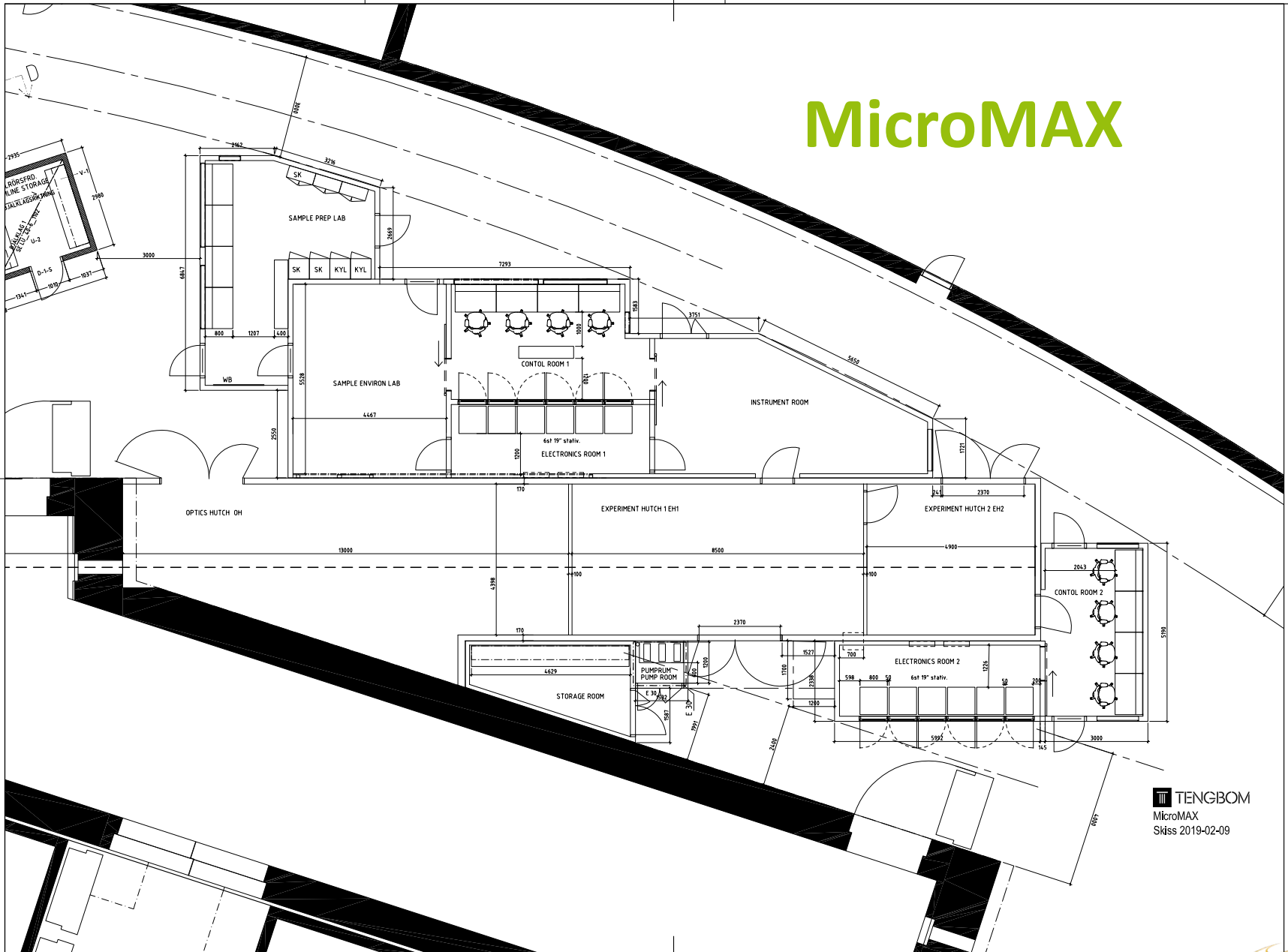

TENG BOM
MicroMAX
Skiss 2019-02-09

MicroMAX

Open position:

Experiment station scientist

<https://www.maxiv.lu.se/about-us/careerjobs/vacancies/>

Application deadline March 24

Beamline/Experimental station scientist MicroMAX temporary (2 year)

Lunds universitet, MAX IV, MX group

Lund University was founded in 1666 and is repeatedly ranked among the world's top 100 universities. The University has 40 000 students and 7 400 staff based in Lund, Helsingborg and Malmö. We are united in our efforts to understand, explain and improve our world and the human condition.

MAX IV is a Swedish national large-scale research laboratory hosted by Lund University. It provides scientists from Sweden as well as internationally, with state-of-the-art instrumentation for research in areas such as engineering, physics, structural biology, chemistry and nanotechnology. Fully developed it will receive more than 2 000 scientists annually, conducting ground-breaking experiments in materials and life sciences using the brilliant X-ray light. As a national laboratory, MAX IV is operated in agreement with governmental regulations, and in compliance with major funders such as the Swedish Research Council (VR) and the Wallenberg Foundation. 250 people are currently employed at MAX IV Laboratory, and 16 beamlines are funded. The facility is in a ramp-up phase with 3 beamlines now receiving users and 13 more scheduled to be commissioned and built to receive users within the next few years. The facility is dimensioned for 25-28 beamlines.

MAX IV Laboratory recently received funding from the Novo Nordisk Foundation (<http://novonordiskfonden.dk/en>) for a new beamline called MicroMAX (<https://www.maxiv.lu.se/micromax/>), a micro-focus macromolecular crystallography beamline. MicroMAX will exploit new sample delivery methods and the unique performance of the MAX IV 3 GeV storage ring to provide new possibilities in collecting high quality structural data from microcrystals.

MicroMAX will build on the rapid development of serial crystallography that is presently attracting great interest within the structural biology community. MicroMAX will not only increase the probability of obtaining structural data from challenging projects where only microcrystals are available but also enable data collection at room temperature and time resolved experiments with a time resolution down to the microsecond range.

The Macromolecular Crystallography (MX) group is responsible for the BioMAX beamline that is in operation and the design, construction and future operation of the MicroMAX beamline. We have started developing activities in the field of serial crystallography and we have already performed experiments at BioMAX.

We are now looking for a beamline scientist to lead the design and construction of the experiment station. We foresee that a permanent position will be advertised in a later stage of the project to finalize the station, take it in user operation and to continue the technical and scientific developments.

Tasks

You will take a leading role in the design and construction of the MicroMAX experiment setup. You will work closely with the MicroMAX research engineer and project manager and other staff within the MicroMAX team and MX group. A major aspect of the experiment setup is the evaluation and implementation of different sample delivery systems that exist and that are being developed by us and the community. An important part of your work will be to create a flexible solution to accommodate these different sample delivery systems, and to incorporate and further develop the different sample delivery systems in collaboration with other members of the MX group and other external collaborating groups. Your work will involve interactions with other groups at MAX IV, collaborating groups and suppliers as well as handling of procurements and administrative tasks.

You will participate in the user support, especially with the already existing serial crystallography environments at BioMAX, and within the on-call service of BioMAX and later MicroMAX.

You are strongly encouraged to develop your own research project and collaborations. Furthermore, you will have to participate in experiments at MAX IV or at other facilities, in particular related to the use and development of serial crystallography or time-resolved crystallography.

Qualifications

Macromolecular Crystallography Group



Mikel Eguraun
Ross Friel
Andrea Gross
Ana Gonzalez
Gustavo Lima
Mirko Milas
Jie Nan
Anastasya Shilova
Johan Unge
Thomas Ursby
Uwe Mueller

Funding MAX IV Facility



MicroMAX funding: **novo nordisk fonden**



Thank you for your attention!